

PITUMEC

THE PCON 745 CONCENTRIC UNDERREAMING SYSTEM

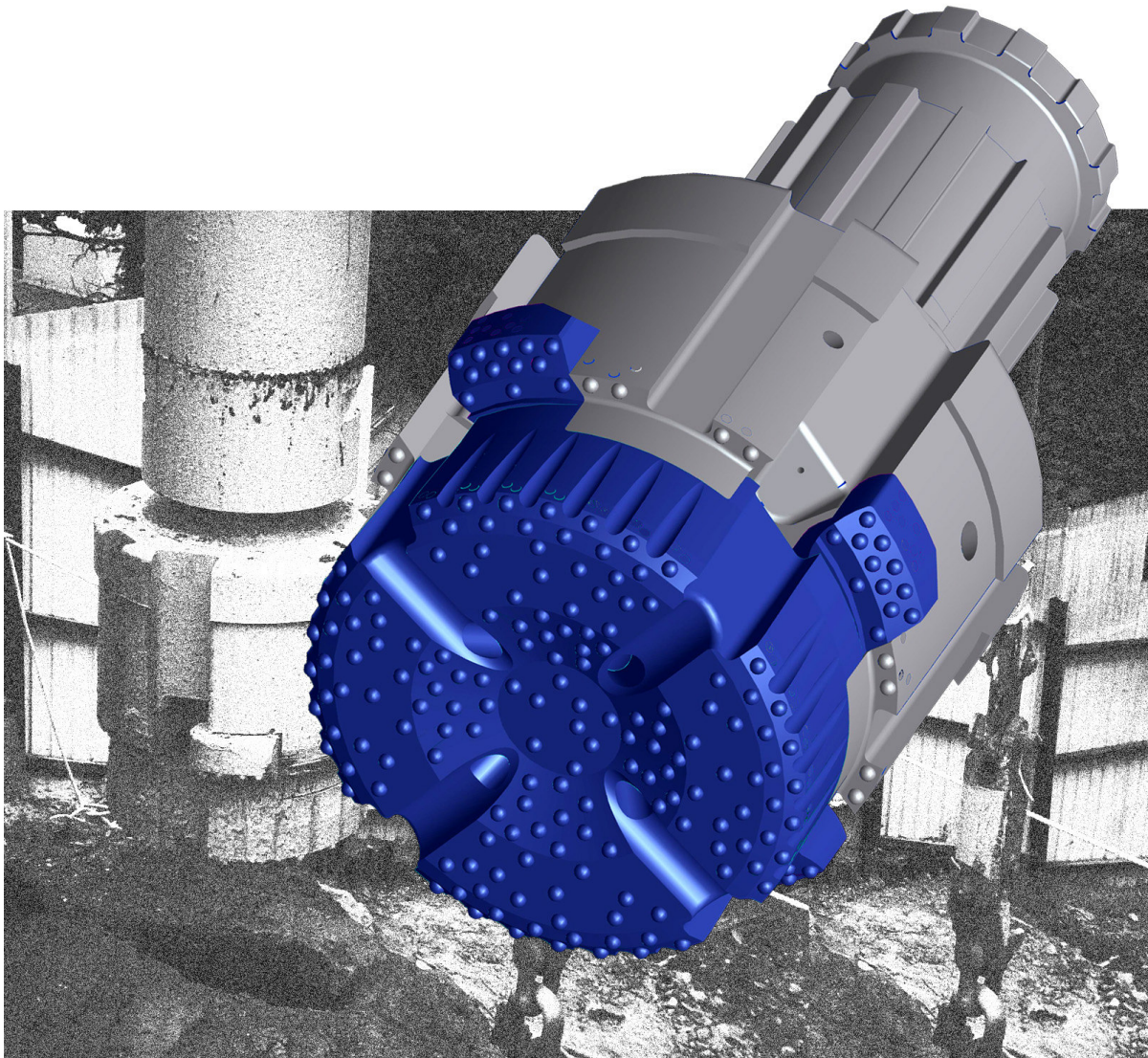

CASING SIZE 813MM OD X 780MM ID DRILLING DIA. 838MM

PNEUMEC PCON 745 CONCENTRIC UNDERREAMING SYSTEM

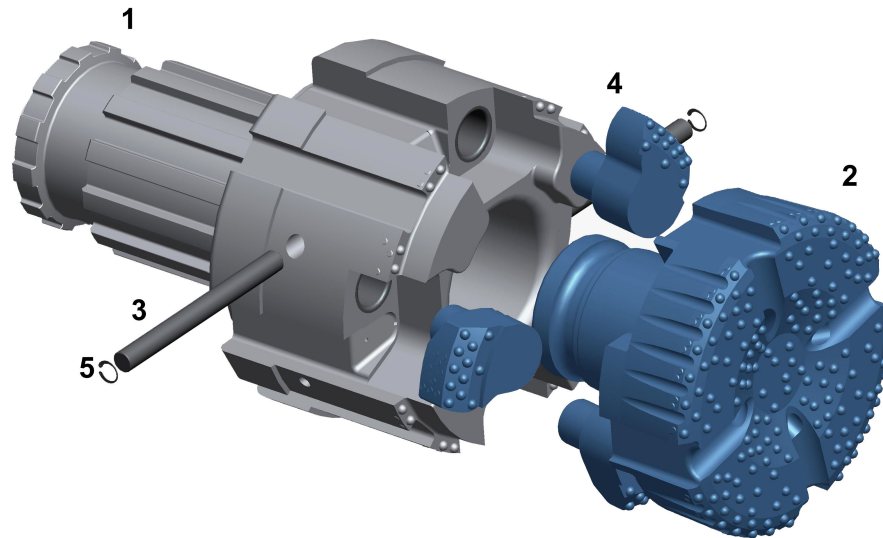

PCON 745 PARTS LIST

1.	GUIDE DEVICE N240 SHANK	UGD745N24PCN
2.	PILOT BIT	UPB745PCN
3.	LOCKING PIN (2)	USP74550PCN
4.	REAMER (4)	UBS745PCN
5.	CIRCLIP (2)	USP74553PCN
6.	COMPLETE SYSTEM N240 SHANK	UCS745N24PCN

PCON 745 SPECIFICATIONS

UPPER BODY DIAMETER	776MM	CLOSED DIAMETER	745MM
REAMING DIAMETER	838MM	CASING SIZE	813MM OD X 780MM ID
SYSTEM LENGTH	1207MM	SYSTEM WEIGHT	2450KG

PCON 745 CASING SHOES

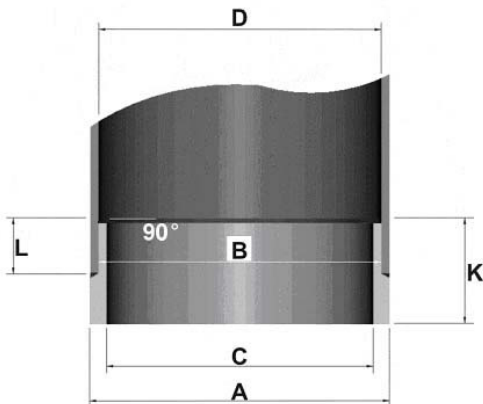

DIA. A	813MM
DIA. B	778.5MM
DIA. C	747MM
DIA. D	780MM
L	105MM
K	195MM

PNEUMEC

PNEUMEC COMPANY LIMITED

1st Floor, Tin On Sing Comm. Bldg., 41-43 Graham St. Central, H.K.

Tel : (852) 2180 9922

Fax : (852) 2180 9982

Website : www.pneumec.com

email : info@pneumec.com